

Light Up Burners

Hamworthy Combustion provides all Light up equipment needed to fire your pulverised fuel boiler, including oil and gas burners, gas and direct spark ignition systems. We can supply equipment for new build and carry out complete retrofitting on existing plant.

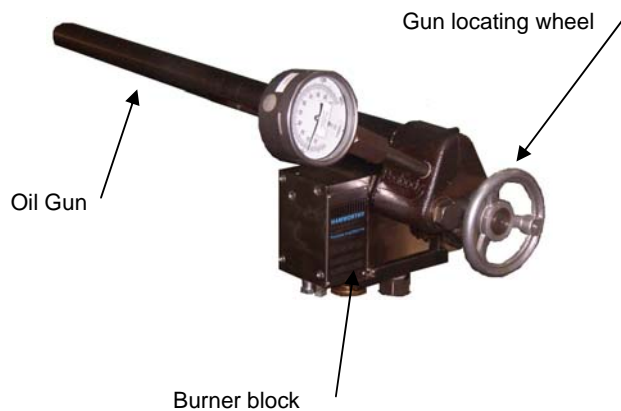

Key Features

- Robust design resilient to damage from the products of combustion
- Full retraction for fuel guns and ignition systems
- Pressure, air or steam atomisation
- Thermal heat release designed to meet requirements
- Easy retrofit into existing plant
- **CE**
- Proven performance



Light Up Burner Flames

Standard Supply

- Fuel gun
- Core air fan
- Retractable igniter
- Burner valves
- Start up shut down panels
- Flame scanner

Standard Questions

- What fuels to be fired
- Performance requirements of burner/boiler
- What the furnace layout is

What must the customer supply/do/have already?

- Boiler details
- Fuel specification
- Burner type required

Specification

- Size - 2MW(th) – 70MW(th)
- Weight - Dependant on burner configuration
- Materials - Carbon Steel/stainless steel

Other Hamworthy Combustion

Services related to this product

- Complete bespoke Burner systems
- Burner ignition systems
- Burner flame detection systems
- Fuel valve trains
- Complete turnkey service
- After Sales back-up

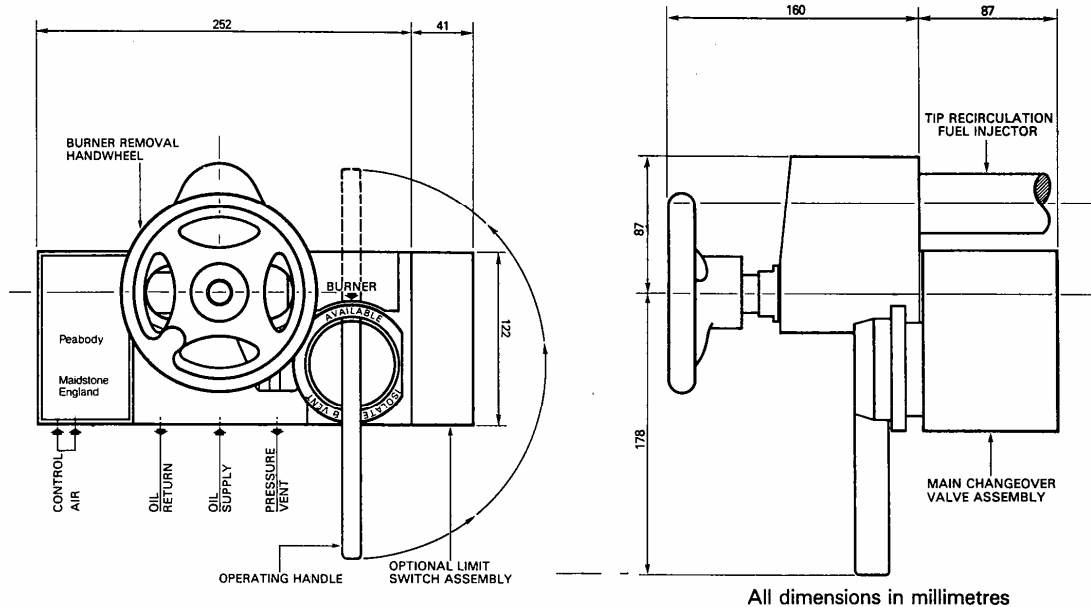

For further information on combustion equipment please contact the head office:

Hamworthy Combustion Engineering Limited
Fleets Corner
Poole Dorset BH17 0LA
Tel: +44 1202 662700
Fax: +44 1202 665333
Email: info@hamworthy-combustion.com
Website: <http://www.hamworthy-combustion.com>

©2008 Hamworthy Combustion Engineering Limited – All rights reserved

Power/Light Up Burners/February 2009/Rev. 1

Hamworthy Combustion Engineering Limited reserve the right to make changes and improvements which may necessitate alteration to the specification without prior notice

HAMWORTHY
COMBUSTION

Incorporating:
PEABODY ENGINEERING
AIROIL - FLAREGAS
CHENTRONICS