

DATASHEET

LNOG Gas / Oil Burner

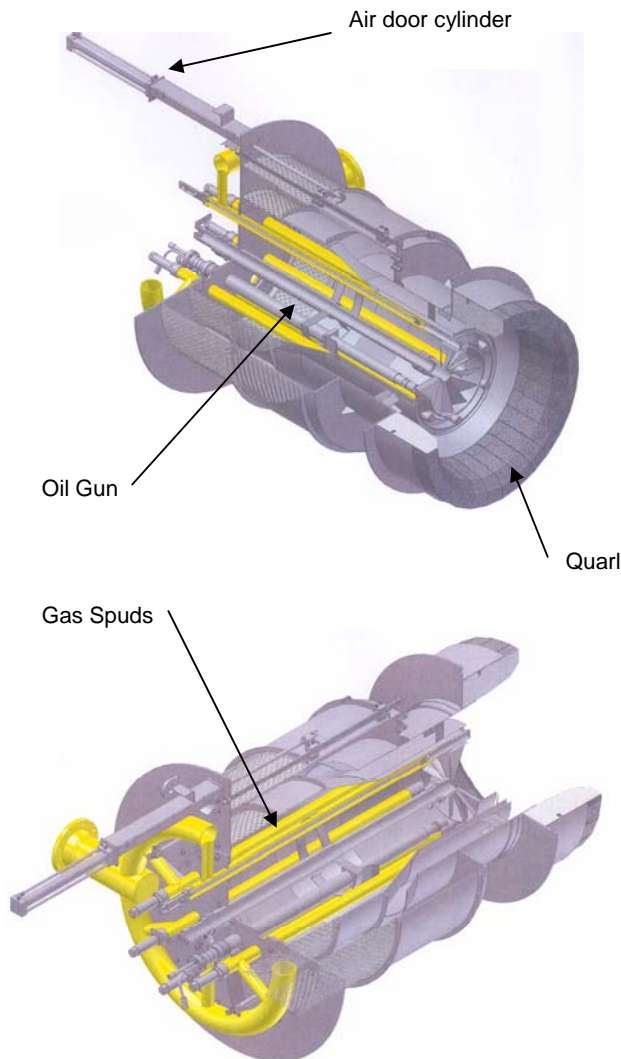

Hamworthy Combustion's LNOG Range of Low emission burners has proven over many years to give outstanding performance in liquid and gaseous firing. We can supply equipment for new build and carry out complete retrofitting on existing plant.



Key Features

- NOx Levels < 140mg Gas Firing
- NOx levels < 450mg HFO Firing
- NOx levels < 250mg LFO Firing
- RFG/steam injection can be added to provide further NOx reductions
- CO Levels < 100ppm
- Thermal heat release 2MW(th) – 100MW(th)
- Intuitive commissioning procedure
- **CE**
- Easy retrofit into existing plant
- Very stable flame
- Proven exceptional performance

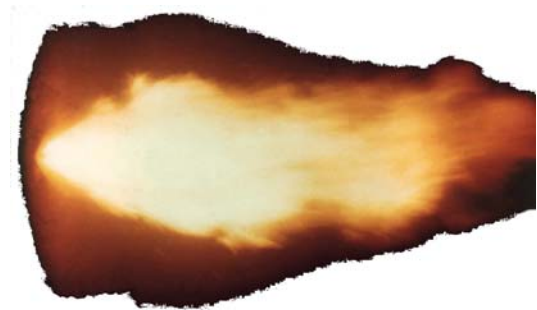

Standard Supply

- Burner
- Windbox
- Oil Gun
- Gas Spuds

Related Questions

- Do I need a proven Low Emission burner?
- What fuels do I fire?
- What fuel pressures do I have?
- What's my combustion air delivery system?
- Am I using existing controls system?
- What are my emission limits?

Specification

- Size - 2MW(th) – 100MW(th)
- Approx. flame length - 3 m– 14m
- Weight - 500Kg approx.
- Materials - Carbon steel / stainless steel

Other Hamworthy Combustion Services

Related to this product

- Complete bespoke Burner Management Systems
- Burner ignition systems
- Burner flame detection systems
- Fuel valve trains
- Complete turnkey service
- After sales back up

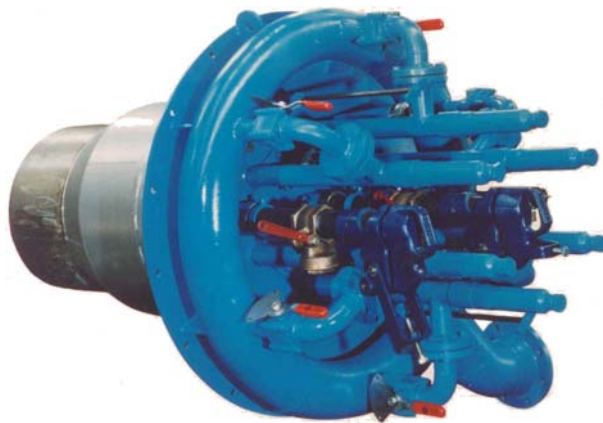

For further information on combustion equipment please contact the head office:

Hamworthy Combustion Engineering Limited
Fleets Corner
Poole Dorset BH17 0LA
Tel: +44 1202 662700
Fax: +44 1202 665333
Email: info@hamworthy-combustion.com
Website: <http://www.hamworthy-combustion.com>

©2008 Hamworthy Combustion Engineering Limited – All rights reserved

Power/LNOG/February 2008/Rev. 1

Hamworthy Combustion Engineering Limited reserve the right to make changes and improvements which may necessitate alteration to the specification without prior notice

HAMWORTHY
COMBUSTION

Incorporating:
PEABODY ENGINEERING
AIROIL - FLAREGAS
CHENTRONICS